



MIC2296

High Power Density 1.2A Boost Regulator

General Description

The MIC2296 is a 600kHz, PWM dc/dc boost switching regulator available in a 2mm x 2mm MLF™ package option. High power density is achieved with the MIC2296's internal 34V / 1.2A switch, allowing it to power large loads in a tiny footprint. The MIC2296 is a version of the MIC2295 1.2MHz, PWM dc/dc boost switching regulator, that offers improved efficiency resulting from 600kHz operation.

The MIC2296 implements constant frequency 600kHz PWM current mode control. The MIC2296 offers internal compensation that offers excellent transient response and output regulation performance. The high frequency operation saves board space by allowing small, low-profile external components. The fixed frequency PWM scheme also reduces spurious switching noise and ripple at the input power source.

The MIC2296 is available in a low-profile Thin SOT23 5-lead package and a 2mm x 2mm 8-lead MLF™ leadless package. The 2mm x 2mm MLF™ package option has an output over-voltage protection feature.

The MIC2296 has an operating junction temperature range of -40°C to $+125^{\circ}\text{C}$

Features

- 2.5V to 10V input voltage range
- Output voltage adjustable to 34V
- 1.2A switch current
- 600kHz PWM operation
- Stable with small size ceramic capacitors
- High efficiency
- Low input and output ripple
- $<1\mu\text{A}$ shutdown current
- UVLO
- Output over-voltage protection (MIC2296BML)
- Over temperature shutdown
- 2mm x 2mm leadless 8-lead MLF™ package option
- -40°C to $+125^{\circ}\text{C}$ junction temperature range

Applications

- Organic EL power supplies
- 3.3V to 5V/500mA conversion
- TFT-LCD bias supplies
- Positive and negative output regulators
- SEPIC converters
- Positive to negative Cuk converters
- 12V supply for DSL applications
- Multi-output dc/dc converters

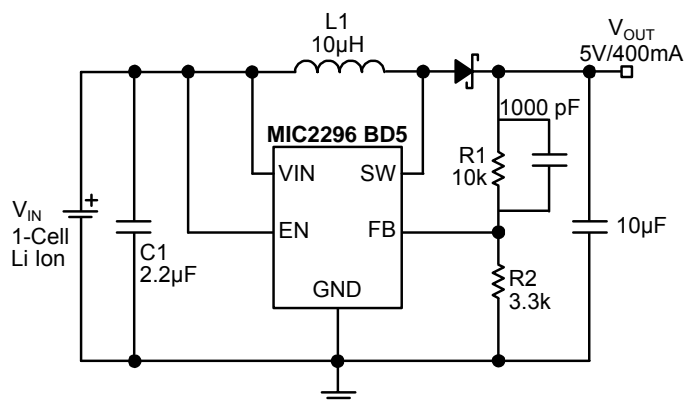
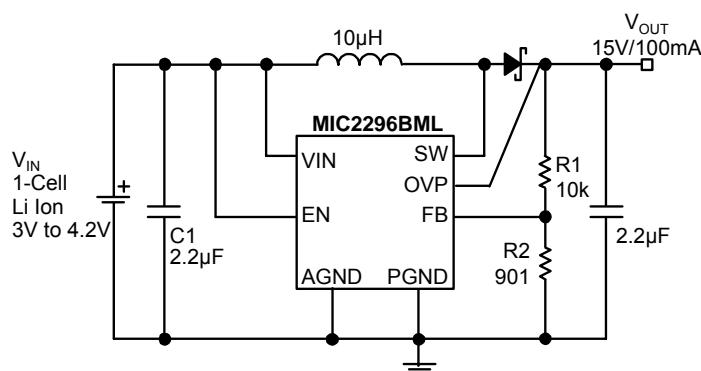

MLF and *MicroLeadFrame* is a trademark of Amkor Technology

Micrel Inc. • 2180 Fortune Drive • San Jose, CA 95131 • USA • tel +1 (408) 944-0800 • fax +1 (408) 474-1000 • <http://www.micrel.com>

April 2005

M9999-042005
(408) 955-1690

Ordering Information

Part Number		Output Over Voltage Protection	Marking Code		Junction Temperature Range	Package
Standard	Lead-Free		Standard	Lead-Free		
MIC2296BML	MIC2296YML	34V	WDA	<u>W</u> DA	-40°C to 125°C	2mm x2mm MLF-8L
MIC2296BD5*	MIC2296YD5*	-	WDAA	<u>W</u> DAA	-40°C to 125°C	Thin SOT-23-5

* Contact factory for availability.

Pin Configuration

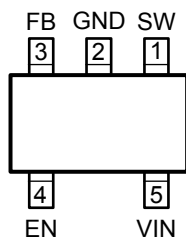

TSOT-23-5 (BD5)

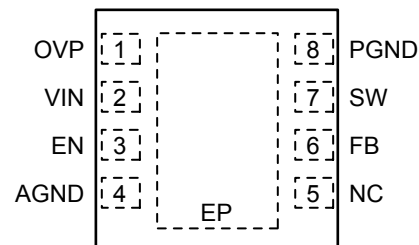

8-pin MLF™ (BML)

Pin Description

MIC2296BD5 Thin SOT-23-5	MIC2296BML 2x2 MLF-8L	Pin Name	Pin Function
—	1	OVP	Output Over-Voltage Protection (Input): Tie this pin to V_{OUT} to clamp the output voltage to 34V maximum in fault conditions. Tie this pin to ground if OVP function is not required.
5	2	VIN	Supply (Input): 2.5V to 10V input voltage.
4	3	EN	Enable (Input): Logic high enables regulator. Logic low shuts down regulator.
—	4	AGND	Analog ground
—	5	N/C	No connect. No internal connection to die.
3	6	FB	Feedback (Input): 1.24V output voltage sense node. $V_{OUT} = 1.24V (1 + R1/R2)$
1	7	SW	Switch Node (Input): Internal power BIPOLAR collector.
—	8	PGND	Power ground
2	—	GND	Ground (Return): Ground.
—	EP	GND	Ground (Return). Exposed backside pad.

Absolute Maximum Rating ⁽¹⁾

Supply voltage (V_{IN}).....	12V
Switch voltage (V_{SW})	-0.3V to 34V
Enable pin voltage (V_{EN}).....	-0.3 to V_{IN}
FB Voltage (V_{FB}).....	.6V
Switch Current (I_{SW})	2.5A
Ambient Storage Temperature (T_S).....	-65°C to +150°C
ESD Rating ⁽³⁾	2KV

Operating Range ⁽²⁾

Supply Voltage (V_{IN}).....	2.5V to 10V
Junction Temperature Range (T_J).....	-40°C to +125°C
Package Thermal Impedance	
θ_{JA} 2x2 MLF-8L lead	93°C/W

Electrical Characteristics ⁽⁴⁾

$T_A=25^\circ\text{C}$, $V_{IN}=V_{EN}=3.6\text{V}$, $V_{OUT}=15\text{V}$, $I_{OUT}=40\text{mA}$, unless otherwise noted. **Bold** values indicate $-40^\circ\text{C} \leq T_J \leq 125^\circ\text{C}$.

Symbol	Parameter	Condition	Min	Typ	Max	Units
V_{IN}	Supply Voltage Range		2.5		10	V
V_{UVLO}	Under-Voltage Lockout		1.8	2.1	2.4	V
I_{VIN}	Quiescent Current	$V_{FB}=2\text{V}$ (not switching)		2.8	5	mA
I_{SD}	Shutdown Current	$V_{EN}=0\text{V}^{(5)}$		0.1	1	μA
V_{FB}	Feedback Voltage	(+/-1%)	1.227	1.24	1.252	V
		(+/-2%) (Over Temp)	1.215		1.265	
I_{FB}	Feedback Input Current	$V_{FB}=1.24\text{V}$		-450		nA
	Line Regulation	$3\text{V} \leq V_{IN} \leq 5\text{V}$		0.04	1	%
	Load Regulation	$5\text{mA} \leq I_{OUT} \leq 40\text{mA}$		0.5		%
D_{MAX}	Maximum Duty Cycle		90	95		%
I_{SW}	Switch Current Limit	Note 5	1.2	1.7	2.5	A
V_{SW}	Switch Saturation Voltage	$I_{SW}=0.5\text{A}$		250		mV
I_{SW}	Switch Leakage Current	$V_{EN}=0\text{V}$, $V_{SW}=10\text{V}$		0.01	1	μA
V_{EN}	Enable Threshold	TURN ON	1.5			V
		TURN OFF			0.4	
I_{EN}	Enable Pin Current	$V_{EN}=10\text{V}$		20	40	μA
f_{SW}	Oscillator Frequency	$V_{IN}=3.6\text{V}$	525	600	675	kHz
V_{OVP}	Output over-voltage protection	MIC2296BML only	30	32	34	V
T_J	Over-Temperature Threshold Shutdown			150		$^\circ\text{C}$
		Hysteresis		10		$^\circ\text{C}$

Notes:

1. Absolute maximum ratings indicate limits beyond which damage to the component may occur. Electrical specifications do not apply when operating the device outside of its operating ratings. The maximum allowable power dissipation is a function of the maximum junction temperature, $T_{J(\text{Max})}$, the junction-to-ambient thermal resistance, θ_{JA} , and the ambient temperature, T_A . The maximum allowable power dissipation will result in excessive die temperature, and the regulator will go into thermal shutdown.
2. This device is not guaranteed to operate beyond its specified operating rating.
3. IC devices are inherently ESD sensitive. Handling precautions required. Human body model rating: 1.5K in series with 100pF.
4. Specification for packaged product only.
5. $I_{SD} = I_{VIN}$.

Typical Characteristics

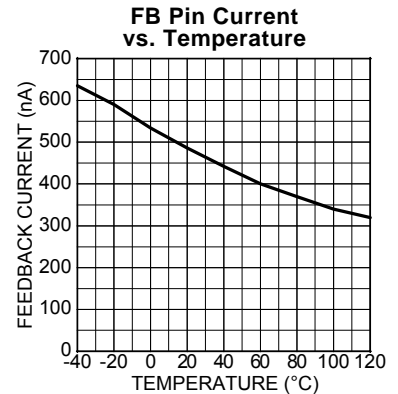
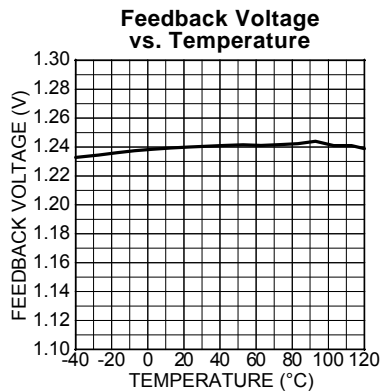
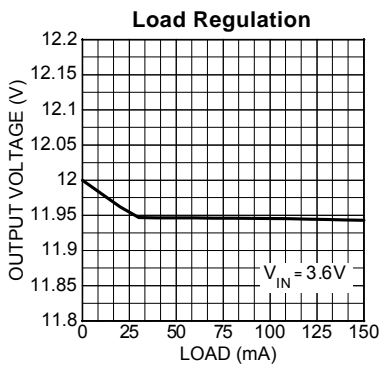
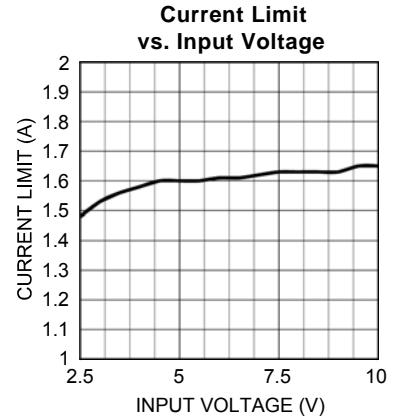
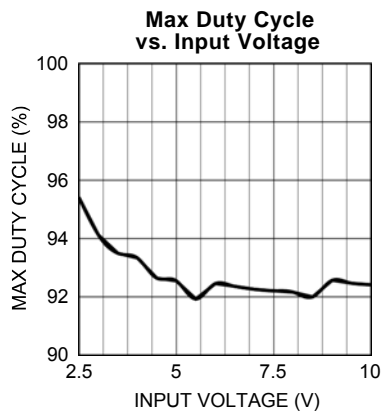
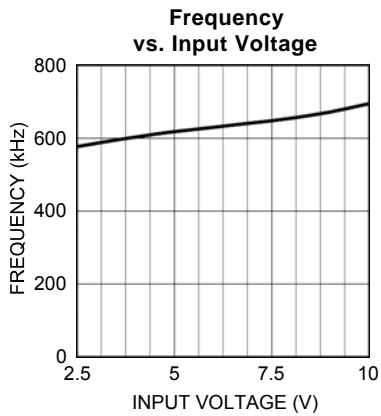
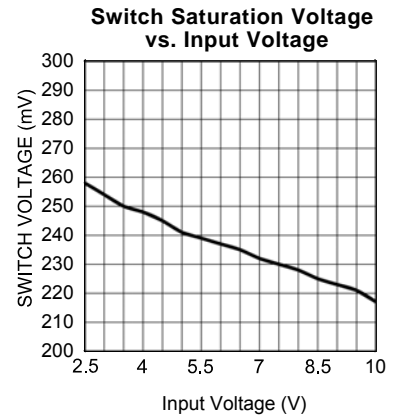
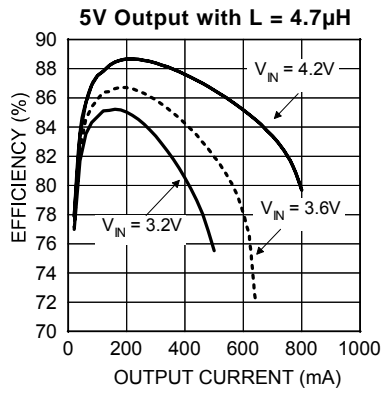
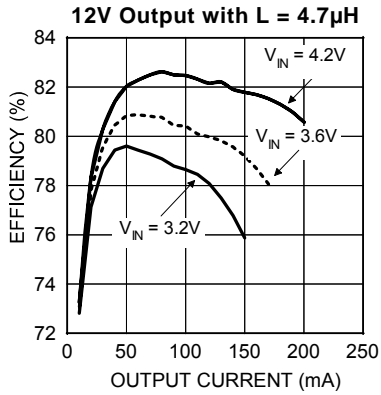

Functional Characteristics

Enable Characteristics

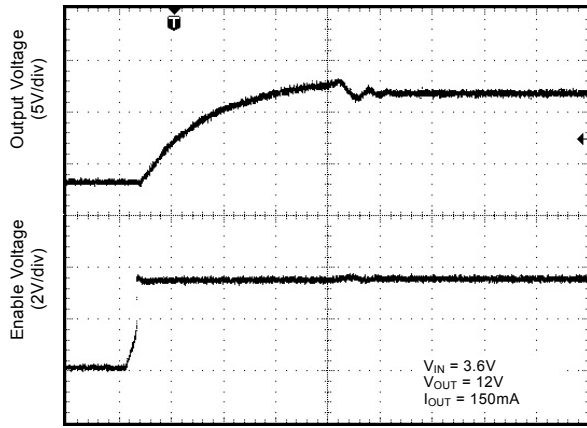

TIME (2 μ s/div)

Step Load Response

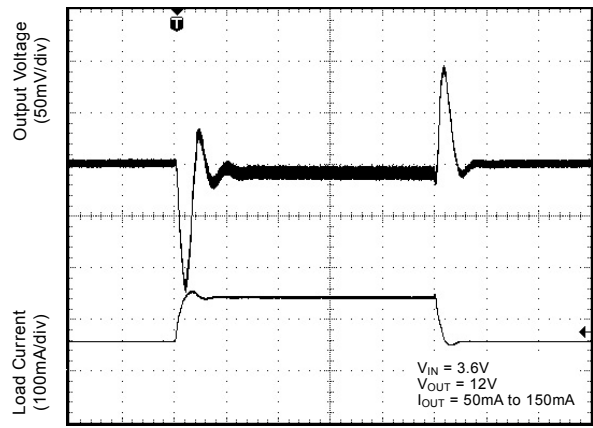

TIME (100 μ s/div)

Functional Description

The MIC2296 is a high power density, PWM dc/dc boost regulator. The block diagram is shown in Figure 1. The MIC2296 is composed of an oscillator, slope compensation ramp generator, current amplifier, gm error amplifier, PWM generator, and a 1.2A bipolar output transistor. The oscillator generates a 600kHz clock. The clock's two functions are to trigger the PWM generator that turns on the output transistor, and to reset the slope compensation ramp generator. The current amplifier is used to measure the switch current by amplifying the voltage signal from the internal sense resistor. The output of the current amplifier is summed with the output of the

slope compensation ramp generator. This summed current-loop signal is fed to one of the inputs of the PWM generator.

The gm error amplifier measures the feedback voltage through the external feedback resistors and amplifies the error between the detected signal and the 1.24V reference voltage. The output of the gm error amplifier provides the voltage-loop signal that is fed to the other input of the PWM generator. When the current-loop signal exceeds the voltage-loop signal, the PWM generator turns off the bipolar output transistor. The next clock period initiates the next switching cycle, maintaining constant frequency current-mode PWM control

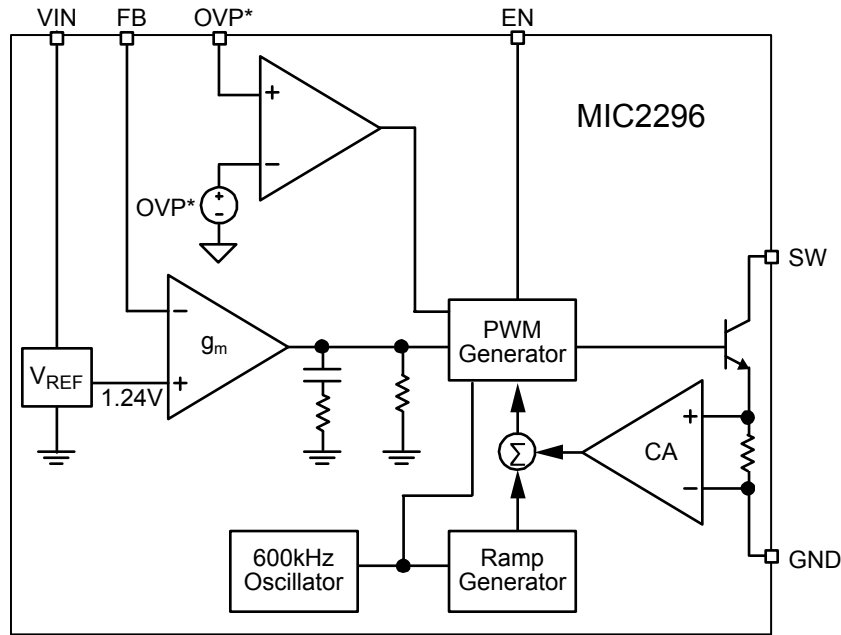

*OVP available on MLF™ package option only.

MIC2296 Block Diagram
Figure 1

Application Information

DC to DC PWM Boost Conversion

The MIC2296 is a constant frequency boost converter. It operates by taking a DC input voltage and regulating a higher DC output voltage. Figure 2 shows a typical circuit.

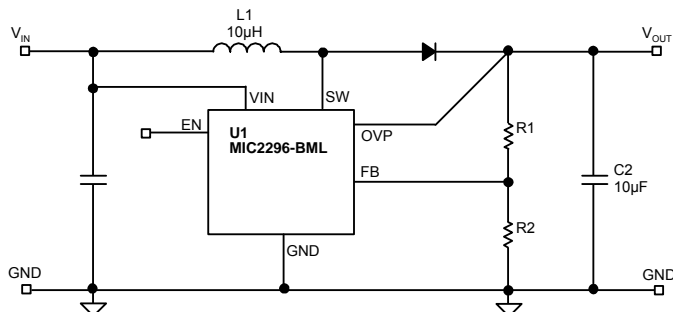

Figure 2

Boost regulation is achieved by turning on an internal switch, which draws current through the inductor (L1). When the switch turns off, the inductor's magnetic field collapses. This causes the current to be discharged into the output capacitor through an external Schottkey diode (D1). Voltage regulation is achieved by modulating the pulse width or pulse width modulation (PWM).

Duty Cycle Considerations

Duty cycle refers to the switch on-to-off time ratio and can be calculated as follows for a boost regulator;

$$D = 1 - \frac{V_{IN}}{V_{OUT}}$$

The duty cycle required for voltage conversion should be less than the maximum duty cycle of 90%. Also, in light load conditions where the input voltage is close to the output voltage, the minimum duty cycle can cause pulse skipping. This is due to the energy stored in the inductor causing the output to overshoot slightly over the regulated output voltage. During the next cycle, the error amplifier detects the output as being high and skips the following pulse. This effect can be reduced by increasing the minimum load or by increasing the inductor value. Increasing the inductor value reduces peak current, which in turn reduces energy transfer in each cycle.

Over Voltage Protection

For MLF package of MIC2296, there is an over voltage protection function. If the feedback resistors are disconnected from the circuit or the feedback pin is shorted to ground, the feedback pin will fall to ground potential. This will cause the MIC2296 to switch at full duty-cycle in an attempt to maintain the feedback voltage. As a result the output voltage will climb out of control. This may cause the switch node voltage to exceed its maximum voltage rating, possibly damaging the IC and the external components. To ensure the highest level of protection, the MIC2296 OVP pin will shut the switch off when an over-

voltage condition is detected saving itself and other sensitive circuitry downstream.

Component Selection

Inductor

Inductor selection is a balance between efficiency, stability, cost, size and rated current. For most applications a 10µH is the recommended inductor value. It is usually a good balance between these considerations. Efficiency is affected by inductance value in that larger inductance values reduce the peak to peak ripple current. This has an effect of reducing both the DC losses and the transition losses.

There is also a secondary effect of an inductor's DC resistance (DCR). The DCR of an inductor will be higher for more inductance in the same package size. This is due to the longer windings required for an increase in inductance. Since the majority of input current (minus the MIC2296 operating current) is passed through the inductor, higher DCR inductors will reduce efficiency.

Also, to maintain stability, increasing inductor size will have to be met with an increase in output capacitance. This is due to the unavoidable "right half plane zero" effect for the continuous current boost converter topology. The frequency at which the right half plane zero occurs can be calculated as follows;

$$F_{rh\,pz} = \frac{V_{IN}^2}{V_{OUT} \times L \times I_{OUT} \times 2\pi}$$

The right half plane zero has the undesirable effect of increasing gain, while decreasing phase. This requires that the loop gain is rolled off before this has significant effect on the total loop response. This can be accomplished by either reducing inductance (increasing RHPZ frequency) or increasing the output capacitor value (decreasing loop gain).

Output Capacitor

Output capacitor selection is also a trade-off between performance, size and cost. Increasing output capacitance will lead to an improved transient response, but also an increase in size and cost. X5R or X7R dielectric ceramic capacitors are recommended for designs with the MIC2296. Y5V values may be used, but to offset their tolerance over temperature, more capacitance is required. The following table shows the recommended ceramic (X5R) output capacitor value vs. output voltage.

Output Voltage	Recommended Output Capacitance
<6V	10µF
<16V	4.7µF
<34V	2.2µF

Diode Selection

The MIC2296 requires an external diode for operation. A Schottky diode is recommended for most applications due to their lower forward voltage drop and reverse recovery time. Ensure the diode selected can deliver the peak inductor current and the maximum reverse voltage is rated greater than the output voltage.

Input Capacitor

A minimum 1 μ F ceramic capacitor is recommended for designing with the MIC2296. Increasing input capacitance will improve performance and greater noise immunity on the source. The input capacitor should be as close as possible to the inductor and the MIC2296, with short traces for good noise performance.

Feedback Resistors

The MIC2296 utilizes a feedback pin to compare the output to an internal reference. The output voltage is adjusted by selecting the appropriate feedback resistor values. The desired output voltage can be calculated as follows;

$$V_{OUT} = V_{REF} \times \left(\frac{R1}{R2} + 1 \right)$$

Where V_{REF} is equal to 1.24V.

Duty-Cycle

The MIC2296 is a general-purpose step up DC-DC converter. The maximum difference between the input voltage and the output voltage is limited by the maximum duty-cycle (D_{max}) of the converter. In the case of MIC2296, $D_{MAX} = 85\%$. The actual duty cycle for a given application can be calculated as follows:

$$D = 1 - \frac{V_{IN}}{V_{OUT}}$$

The actual duty-cycle, D, cannot surpass the maximum rated duty-cycle, D_{max} .

Output Voltage Setting

The following equation can be used to select the feedback resistors R1 and R2 (see figure 1).

$$R_1 = R_2 \cdot \left[\frac{V_{OUT}}{1.24V} - 1 \right]$$

A high value of R2 can increase the whole system efficiency, but the feedback pin input current (I_{FB}) of the gm operation amplifier will affect the output voltage. The R2 resistor value must be less than or equal to 5k Ω ($R2 \leq 5k\Omega$).

Inductor Selection

In MIC2296, the switch current limit is 1.2A. The selected inductor should handle at least 1.2A current without saturating. The inductor should have a low DC resistor to minimize power losses. The inductor's value can be 4.7 μ H to 10 μ H for most applications.

Capacitor Selection

Multi-layer ceramic capacitors are the best choice for input and output capacitors. They offer extremely low ESR, allowing very low ripple, and are available in very small, cost effective packages. X5R dielectrics are preferred. A 4.7 μ F to 10 μ F output capacitor is suitable for most applications.

Diode Selection

For maximum efficiency, Schottky diode is recommended for use with MIC2296. An optimal component selection can be made by choosing the appropriate reverse blocking voltage rating and the average forward current rating for a given application. For the case of maximum output voltage (34V) and maximum output current capability, a 40V / 1A Schottky diode should be used.

Open-Circuit Protection

For MLF package option of MIC2296, there is an output over-voltage protection function that clamps the output to below 34V in fault conditions. Possible fault conditions may include: if the device is configured in a constant current mode of operation and the load opens, or if in the standard application the feedback resistors are disconnected from the circuit. In these cases the FB pin will pull to ground, causing the MIC2296 to switch with a high duty-cycle. As a result, the output voltage will climb out of regulation, causing the SW pin to exceed its maximum voltage rating and possibly damaging the IC and the external components. To ensure the highest level of safety, the MIC2296 has a dedicated pin, OVP, to monitor and clamp the output voltage in over-voltage conditions. The OVP function is offered in the 2mm x 2mm MLF-8L package option only. To disable OVP function, tie the OVP pin to ground

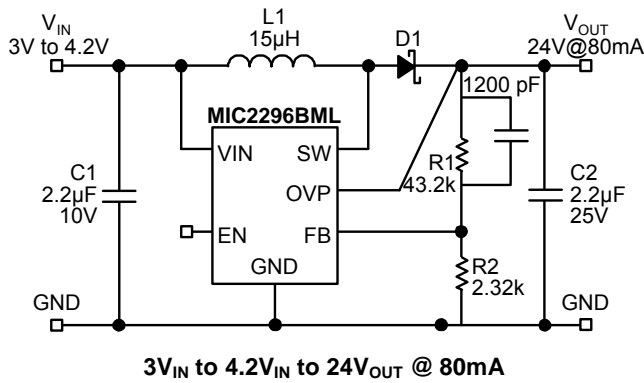
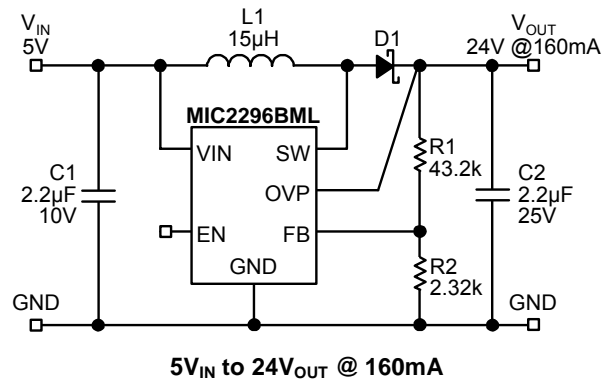
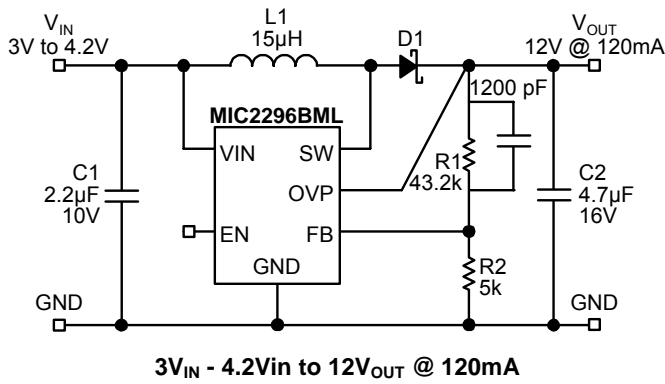
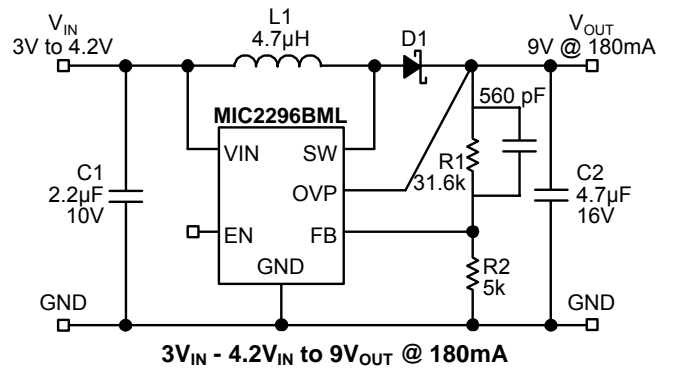
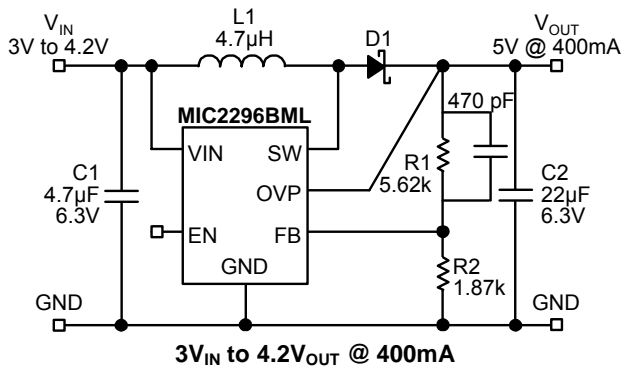

Package Information

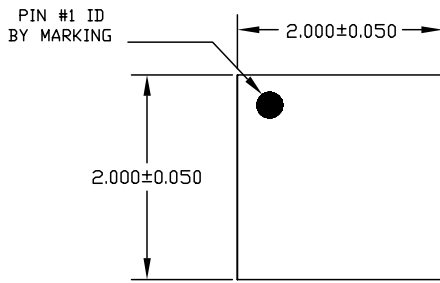

TOP VIEW

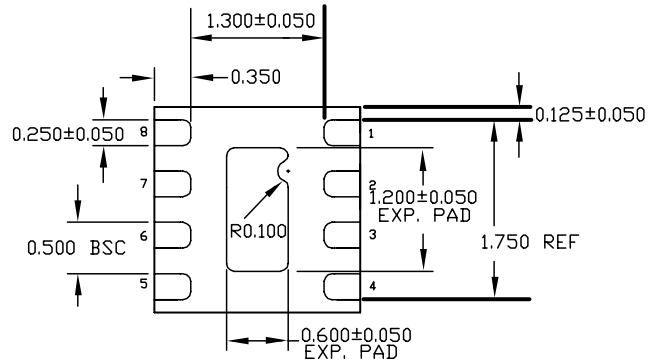

BOTTOM VIEW

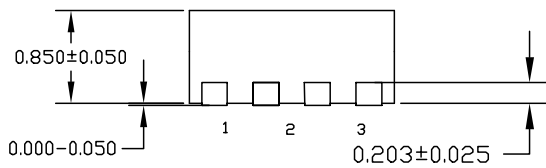

SIDE VIEW

NOTE:

1. ALL DIMENSIONS ARE IN MILLIMETERS.
2. MAX. PACKAGE WARPAGE IS 0.05 mm.
3. MAXIMUM ALLOWABLE BURRS IS 0.076 mm IN ALL DIRECTIONS.
4. PIN #1 ID ON TOP WILL BE LASER/INK MARKED.

8-Pin Package MLF (ML)

MICREL, INC. 2180 FORTUNE DRIVE SAN JOSE, CA 95131 USA
 TEL +1 (408) 944-0800 FAX +1 (408) 474-1000 WEB <http://www.micrel.com>

The information furnished by Micrel in this data sheet is believed to be accurate and reliable. However, no responsibility is assumed by Micrel for its use. Micrel reserves the right to change circuitry and specifications at any time without notification to the customer.

Micrel Products are not designed or authorized for use as components in life support appliances, devices or systems where malfunction of a product can reasonably be expected to result in personal injury. Life support devices or systems are devices or systems that (a) are intended for surgical implant into the body or (b) support or sustain life, and whose failure to perform can be reasonably expected to result in a significant injury to the user. A Purchaser's use or sale of Micrel Products for use in life support appliances, devices or systems is a Purchaser's own risk and Purchaser agrees to fully indemnify Micrel for any damages resulting from such use or sale.

© 2005 Micrel, Incorporated.